

A Five-Level MILP Model for Flexible Transmission Network Planning Under Uncertainty: A Min–Max Regret Approach

Alexandre Moreira ^{id}, *Student Member, IEEE*, Goran Strbac, *Member, IEEE*, Rodrigo Moreno ^{id}, *Member, IEEE*, Alexandre Street ^{id}, *Senior Member, IEEE*, and Ioannis Konstantelos, *Member, IEEE*

Abstract—The benefits of new transmission investment significantly depend on deployment patterns of renewable electricity generation that are characterized by severe uncertainty. In this context, this paper presents a novel methodology to solve the transmission expansion planning problem under generation expansion uncertainty in a min–max regret fashion, when considering flexible network options and $n - 1$ security criterion. To do so, we propose a five-level mixed integer linear programming (MILP) based model that comprises: (i) the optimal network investment plan (including phase shifters), (ii) the realization of generation expansion, (iii) the co-optimization of energy and reserves given transmission and generation expansions, (iv) the realization of system outages, and (v) the decision on optimal post-contingency corrective control. In order to solve the five-level model, we present a cutting plane algorithm that ultimately identifies the optimal min–max regret flexible transmission plan in a finite number of steps. The numerical studies carried out demonstrate: (a) the significant benefits associated with flexible network investment options to hedge transmission expansion plans against generation expansion uncertainty and system outages, (b) strategic planning-under-uncertainty uncovers the full benefit of flexible options which may remain undetected under deterministic, perfect information methods, and (c) the computational scalability of the proposed approach.

Index Terms—Multi-level optimization, network security, power systems economics, transmission expansion planning under uncertainty.

Manuscript received August 24, 2016; revised January 9, 2017 and April 4, 2017; accepted May 20, 2017. Date of publication June 1, 2017; date of current version December 20, 2017. The work of A. Moreira, G. Strbac, I. Konstantelos, and R. Moreno (the Imperial College team) was supported by the Engineering and Physical Sciences Research Council under Grant EP/K002252/1 and Grant EP/N005996/1. The work of A. Moreira was supported by CNPq – Brazil under the *Science without Borders* scholarship program, Grant 203274/2014-8. The work of R. Moreno was supported in part by Grant Fondect/Iniciacion/11130612, in part by Grant Newton-Picarte/MR/N026721/1, in part by Grant Fondecyt/ID15110592, in part by Grant SERC Fondap/15110019, and in part by the Complex Engineering Systems Institute (CONICYT – PIA – FB0816; ICM P-05-004-F). The work of A. Street was partially supported by the National Council for Research and Development, CNPq, Brazil. Paper no. TPWRS-01291-2016. (*Corresponding author: Alexandre Moreira.*)

A. Moreira (CNPq Scholarship Student – Brazil), G. Strbac, and I. Konstantelos are with Imperial College London, London SW7 2AZ, U.K. (e-mail: a.moreira14@imperial.ac.uk; g.strbac@imperial.ac.uk; i.konstantelos@imperial.ac.uk).

R. Moreno is with the Universidad de Chile, Santiago, Chile, and also with Imperial College London, London SW7 2AZ, U.K. (e-mail: rmorenovieyra@ing.uchile.cl).

A. Street is with the Pontifical Catholic University of Rio de Janeiro, Rio de Janeiro, RJ 22430-060, Brazil (e-mail: street@ele.puc-rio.br).

Digital Object Identifier 10.1109/TPWRS.2017.2710637

NOMENCLATURE

The mathematical symbols used throughout this paper are classified below as follows.

Functions

$I(\cdot)$ Investment cost function.
 $MaxReg(\cdot)$ Maximum regret function.

Sets

I Set of indexes of all generators, equal to $(I_c \cup I_w)$.
 I_b Set of indexes of generators connected to bus b .
 I_c Set of indexes of conventional power plants.
 I_w Set of indexes of potential new renewable generators.
 \mathcal{L} Set of indexes of all transmission lines, equal to $(\mathcal{L}^C \cup \mathcal{L}^F \cup \mathcal{L}^{PS})$.
 \mathcal{L}^C Set of indexes of transmission lines that are candidate to be built.
 \mathcal{L}^F Set of indexes of fixed existing transmission lines, i.e., existing lines that are not candidate for placement of phase shifters.
 \mathcal{L}^{PS} Set of indexes of existing transmission lines that are candidate for placement of phase shifters.
 N Set of indexes of buses.

Parameters

$\bar{\psi}$ Capacity limit of phase shifters.
 C_l^{Cap} Annual cost per MW of candidate line l .
 C_i^D Reserve-down cost of generator i .
 C_l^{fix} Annual fixed cost of installation of candidate transmission asset l .
 C^I Cost of system power imbalance.
 C_i^P Production cost of generator i .
 C^S Cost of wind spillage.
 C_i^U Reserve-up cost of generator i .
 D_{bt} Demand at bus b , during snapshot t .
 d_t Number of hours of snapshot t .
 \bar{F}_l Power flow capacity of existing line l .
 \bar{F}_l^C Maximum power flow capacity of candidate line l .
 $fr(l)$ Sending or origin bus of line l .
 \bar{P}_i Capacity of generator i .
 R_i^D Reserve-down limit of generator i .
 R_i^U Reserve-up limit of generator i .

$to(l)$	Receiving or destination bus of line l .
\overline{W}_{its}	Available capacity of renewable generator i at snapshot t in scenario s .
x_l	Reactance of line l .

Decision Variables

Δ_t	System power imbalance at snapshot t under the worst-case contingency given a transmission expansion plan, a generation expansion realization, and a scheduling of power and reserves.
ΔD_t^{wc}	System power imbalance at snapshot t under the worst-case contingency given a transmission expansion plan, a generation expansion realization, and a scheduling of power and reserves.
ΔD_{bt}^+	Power surplus at bus b , at snapshot t .
ΔD_{bt}^-	Power deficit at bus b , at snapshot t .
θ_{bt}	Phase angle at bus b , at snapshot t , in the pre-contingency state.
θ_{bt}^{wc}	Phase angle at bus b , at snapshot t , under the worst-case contingency given a transmission expansion plan, a generation expansion realization, and a scheduling of power and reserves.
ψ_{lt}	Phase-shifting angle in line l , at snapshot t , in the pre-contingency state.
ψ_{lt}^{wc}	Phase-shifting angle in line l , at snapshot t , under the worst-case contingency given a transmission expansion plan, a generation expansion realization, and a scheduling of power and reserves.
a_{it}^G	Binary variable that is equal to 0 if generator i is unavailable at snapshot t under the worst-case contingency, given a transmission expansion plan, a generation expansion realization, and a scheduling of power and reserves, being 1 otherwise.
a_{lt}^L	Binary variable that is equal to 0 if line l is unavailable at snapshot t under the worst-case contingency, given a transmission expansion plan, a generation expansion realization, and a scheduling of power and reserves, being 1 otherwise.
f_{lt}	Power flow of line l , at snapshot t , in the pre-contingency state.
f_l^C	Power flow capacity of candidate line l .
f_{lt}^{wc}	Power flow of line l , at snapshot t , under the worst-case contingency given a transmission expansion plan, a generation expansion realization, and a scheduling of power and reserves.
p_{it}	Power output of generator i , at snapshot t , in the pre-contingency state.
p_{it}^{wc}	Power output of generator i , at snapshot t , under the worst-case contingency given a transmission expansion plan, a generation expansion realization, and a scheduling of power and reserves.
r_{it}^d	Down-spinning reserve provided by generator i , at snapshot t .
r_{it}^u	Up-spinning reserve provided by generator i , at snapshot t .

v_l	Binary variable that is equal to 1 if candidate transmission asset l is installed, being 0 otherwise.
-------	---

Dual Variables

β_{bt}	Dual variable associated with the power balance equation at bus b , at snapshot t , under the worst-case contingency given a transmission expansion plan, a generation expansion realization, and a scheduling of power and reserves.
$\gamma_{it}^+, \gamma_{it}^-$	Dual variables associated with the constraints imposing the lower and upper bounds on p_{it}^{wc} for generating unit i .
η_{it}^+, η_{it}^-	Dual variables associated with the constraints imposing the lower and upper bounds on ψ_{lt}^{wc} for line l .
ξ_{its}^+, ξ_{its}^-	Dual variables associated with the lower- and upper-bound constraints for transmission in candidate line l , at snapshot t , in scenario s of generation expansion.
π_{it}^+, π_{it}^-	Dual variables associated with the constraints imposing the lower and upper bounds on f_{lt}^{wc} for existing line l .
$\rho_{lts}^+, \rho_{lts}^-$	Dual variables associated with the lower- and upper-bound constraints relating power flow and phase angles for candidate line l , at snapshot t , in scenario s of generation expansion.
$\sigma_{lt}^+, \sigma_{lt}^-$	Dual variables associated with the lower- and upper-bound constraints relating power flow and phase angles for candidate line l , at snapshot t , under the worst-case contingency given a transmission expansion plan, a generation expansion realization, and a scheduling of power and reserves.
$\phi_{lts}^+, \phi_{lts}^-$	Dual variables associated with the lower- and upper-bound constraints for phase-shifting in candidate line l , at snapshot t , in scenario s of generation expansion.
χ_{lt}^+, χ_{lt}^-	Dual variables associated with the constraints imposing the lower and upper bounds on f_{lt}^{wc} for candidate line l .
ω_{lt}	Dual variable associated with the equation relating power flow and phase angles for existing line l , at snapshot t , under the worst-case contingency given a transmission expansion plan, a generation expansion realization, and a scheduling of power and reserves.

I. INTRODUCTION

TRANSMISSION expansion plays a key role in integrating growing volumes of renewable energy sources (RES) and thus in decarbonizing power systems. Planning new transmission assets to integrate RES, however, has become increasingly difficult due to mid- and long-term uncertainties associated with the amount and location of deployment of renewable generation [1]–[3]. Additionally, network design has to be secured [4], [5] which refers to the need to withstand outages of components through an efficient portfolio of preventive and corrective actions. As a consequence, there is growing interest

in system models that can inform future transmission network planning in order to accommodate the forthcoming renewable generation (that is uncertain) in an economically efficient and secured fashion. In this context, this paper proposes a novel optimization model for transmission expansion planning (TEP) based on the concept of min-max regret [6] that considers uncertainties associated with future generation expansion while taking into account deterministic security standards.

It is well-known that the TEP problem is a complex task. In the technical literature, a great deal of effort has been devoted to deal with various aspects related to this problem [7], [8]. Within this context, multi-level formulations have been proposed to address expansions of network infrastructures. Works [9]–[11] are some of the relevant examples of bilevel approaches for TEP. In [9], a bilevel approach was proposed to minimize costs associated with the transmission expansion plan while facilitating trades in the electricity market. In [10], the framework presented in [9] was extended by the inclusion of security constraints. In [11], the authors used a bilevel framework to model the efficiency benefit (benefit of accessing lower cost distant generation) and the competition benefit (benefit of improving competition among generators) associated with additional transmission capacity. In addition, trilevel models such as [12]–[14] were also presented to tackle the TEP problem. In [12], a trilevel model was developed to determine the transmission expansion plan while considering the equilibria associated with generation expansion and pool-based market clearing. In [13], a trilevel formulation was proposed to address the TEP problem under uncertainty in demand and in available generation capacity of existing generating units. In [14], the TEP problem was tackled under uncertainty in future generation investments without considering security standards. In this paper, we aim to provide a methodology that determines the transmission expansion plan that minimizes the maximum regret of the planner under generation expansion uncertainty while securing operation. Due to the challenges associated with this objective, we move beyond the current literature and present in this paper a novel 5-level optimization model for the TEP problem.

Recent works have addressed transmission expansion planning to comply with reliability standards [4], [5]. In [4], a trilevel model to plan transmission investments under uncertain demand and wind generation is proposed. In order to tackle the problem of expanding transmission infrastructure while complying with deterministic $n - K$ security criterion, [5] proposed a two-stage robust optimization model to consider all possible generation and transmission contingencies in the transmission expansion planning framework. Despite the relevance of the aforementioned works, they did not consider opportunities for investment in flexible alternating current transmission system (FACTS) devices, which can improve the flexibility of the transmission network to deal with uncertainty and also support delivery of system security requirements at efficient cost.

In effect, the role of FACTS devices has received considerable attention in recent literature [15]–[19]. In [15], the DC optimal power flow (DC-OPF) problem is formulated as a non-linear model, which is then recast as a MILP, effectively representing the role of FACTS in providing flexibility and hence reducing

operating costs. In [16], an approach for deciding day-ahead dispatch that considers FACTS devices to facilitate corrective actions is proposed. In [17], the authors provide an assessment of the benefits of flexible DC and AC transmission assets when considering post-contingency control of FACTS setpoints. On the transmission planning side, [18] presents a MILP model to address the TEP problem considering series compensation devices among the candidate transmission assets without imposing security criteria. In [19], a stochastic TEP model is proposed to assess the value of incorporating flexible assets to the grid. The importance of the aforementioned progresses notwithstanding, determining optimal portfolios of conventional and flexible network investments while optimizing pre- and post-fault operational measures (from generation and network components) to efficiently and securely deal with long-term uncertainties (volume and location of future generation) and system failures has not yet been addressed.

Under a contingency state, besides deciding the set of post-contingency corrective actions, system operators must also ensure deliverability of scheduled reserves in order to match supply and demand post-fault without overloading network infrastructure. In some conditions, however, it may be difficult to guarantee deliverability of reserves while respecting Kirchhoff's laws due to the presence of network loop flows as shown in [20]. In this case, the flexibility provided by FACTS devices may play a fundamental role, offering the necessary leeway to ensure supply-demand balance while complying with network constraints following the occurrence of an outage of any generation plant or transmission circuit. Thus, this paper analyses the possibility of investing in phase shifters alongside transmission lines to reinforce the grid.

The value of the notion of regret as an approach to measure risk in decision making under uncertainty has already been recognized in the classical academic literature [21], [22]. In the context of expansion planning models for power systems, approaches based on the minimization of the maximum regret have been proposed in the nineties [23] for generation expansion planning and recently for transmission expansion planning [2], [24]. In addition, in industry, the min-max regret has also been already accepted as the most appropriate metric for transmission expansion planning by the major player of the power sector in the UK, namely National Grid [25], [26]. Despite the relevance of the aforementioned academic works, they do not consider all the features that are simultaneously included in our proposed methodology. These features are: (i) the determination of the transmission expansion plan that minimizes the regret of the system planner under uncertainty in future generation expansion; (ii) the inclusion of deterministic security criterion ($n - K$) to better characterize the operational side while planning the transmission expansion; (iii) the incorporation of flexible devices among the candidate transmission assets to provide better controllability of the transmission grid; (iv) and the consideration of the balance between scheduling spinning reserves and investing in transmission assets. The simultaneous inclusion of all the aforementioned features in a single methodology is a key factor that allows in the planning stage the consideration of the value of investing in transmission assets that increase

operational flexibility. The benefit of considering these features in the transmission expansion problem notwithstanding, it implies significant challenges mostly due to computational burden since the number of constraints to represent them may render the problem intractable. To circumvent these challenges, in this paper, we propose a five-level formulation for the TEP problem considering features (i) to (iv), which precisely reproduce the decision process hierarchy faced by the decision maker, and a solution methodology based on a decomposition scheme capable to provide near-optimal solutions with moderate computational effort.

Regarding the min-max regret approach utilized by National Grid, it should be noted that such approach is a heuristic process that cannot guarantee optimality. As described in [26], National Grid considers only a few candidate transmission plans. Each of these plans is obtained by selecting an individual scenario of generation expansion and identifying the best transmission expansion plan for this particular scenario under perfect information. Then, the regret of using the best solution of one particular scenario is evaluated under the realization of the other scenarios. This process is repeated for each candidate transmission plan (there is one candidate transmission plan per scenario under perfect information). The preferred option is then chosen in [26] as the option that leads to the minimum maximum regret. This approach may be narrow in scope since it may disregard investments that have potential to minimize the maximum regret but do not appear in any of the solutions under perfect information. The need for considering in the planning model many operational details, which significantly affect the investment plan and therefore need to be considered, imposes computational challenges that justify the use of a heuristic process. However, this choice also imposes sub-optimality. Hence, we propose a methodology that truly minimizes the maximum regret by considering all possible transmission plans (i.e., all possible combinations of candidate transmission assets) to minimize the maximum regret in our proposed optimization model while considering relevant details from the operational side that affect the evaluation of the resulting operational cost.

The concept of minimizing the maximum regret in the TEP problem under uncertainty in future generation capacity has already been addressed in [2], which also provides a comprehensive comparison between min-max cost and min-max regret approaches.

Likewise, the methodology proposed in the present work also considers the TEP problem under uncertainty in future generation capacity. However, this paper is different to [2] in four remarkable aspects. Firstly, unlike [2], we consider industry reliability practices and model deterministic $n - 1$ security criterion, i.e., the resulting transmission plan effectively provides system operators with necessary set of preventive and corrective actions to withstand any credible outage while planning the system dispatch. Secondly, flexible network investment is considered through phase shifters that are included in the array of candidate transmission assets, and this is critical to efficiently deal with contingencies and long-term uncertainty in volume and location of RES. Thirdly, the scheduling of spinning reserves is taken into account so that the trade-off between

operational measures (scheduling reserves) and installing new transmission assets can be truly optimized. Finally, instead of considering continuous intervals of future newly added capacity, our proposition accounts for a set of discrete, credible expansion scenarios.¹ Regarding the discrete set of generation expansion scenarios, it is worth mentioning that we do not claim that this proposed approach to represent the uncertainty in generation expansion is more (or less) appropriate than that proposed in [2]. Instead, we argue that our approach constitutes an interesting alternative that is in line with current industry practices. Moreover, it is important to highlight that the consideration of security criteria in the min-max regret model implies significant changes in the modeling structure as compared to [2], regardless of the scenarios considered for generation expansion. Hence, the 5-level optimization model and the solution algorithm proposed in this paper are required to deal with the improvements carried out.

Hence, the main contributions of this paper are:

- 1) A novel 5-level MILP formulation that represents the min-max regret TEP problem under generation expansion uncertainty while imposing $n - 1$ security criterion. It is worth mentioning that the proposed model is sufficiently general to consider $n - K$ security, however, in this work, we focus on $n - 1$ security. The solution for the proposed model determines optimal portfolios of conventional and flexible network investments (e.g., phase shifters) while optimizing pre- and post-fault operational measures (from both generation and phase shifters) to efficiently and securely deal with long-term uncertainties (volume and location of future generation deployment) and system failures. It should be emphasized that in the literature all the aforementioned features have not been addressed yet in the same model.
- 2) A solution method that effectively determines the global optimal solution of the proposed 5-level model in a finite number of iterations. This solution method is based on Benders decomposition to obtain the optimal transmission expansion plan and on column and constraint generation to impose a deterministic security criterion.

The remainder of the paper is organized as follows. Section II presents the 5-level framework proposed; Section III shows the mathematical formulation; and Section IV describes the proposed solution methodology. In Section V, we present the case studies and finally, in Section VI, we conclude.

II. 5-LEVEL FRAMEWORK

As discussed in [27], the time required to install new renewable generation can be considerably shorter than that required to build new network infrastructure. As a result, network planners may have to take transmission expansion decisions in advance

¹In the UK, for instance as explained in [26], National Grid represents uncertainty in future generation capacity by means of four representative plausible scenarios. These scenarios are developed after an extensive consultation of industry experts. In this paper, we also use a discrete set of scenarios following this industry practice. However, the generation of such scenarios is out of the scope of this paper. We aim to provide a methodology for which these scenarios are an input. The scenarios used in this paper are illustrative.

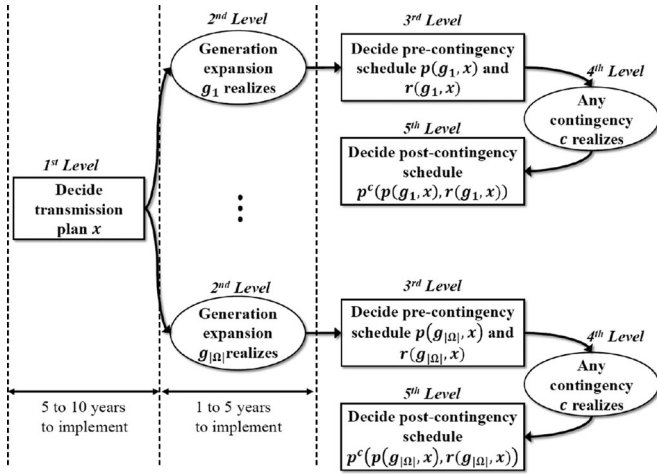

Fig. 1. Framework diagram.

of generation investments (and therefore under uncertainty). In this context, the proposed framework minimizes exposure to the two following conditions that may lead to increased regret: (i) cost of stranded network assets in case that future generation is not fully deployed, and (ii) increased congestion and renewable resource curtailment costs in case that new RES is deployed without the adequate network investment. In order to minimize the exposure to these regrets, the proposed framework explicitly considers the uncertainty associated with future generation expansion in terms of amount and location. Additionally, our framework plans secured network infrastructure since it considers all credible $(n - 1)$ outages and contingencies of system components. Hence, we propose a methodology to minimize the maximum regret in the TEP problem while securing network operation. In order to do so, this methodology determines an optimal portfolio of conventional and flexible network investments. The determination of this portfolio takes into account the optimization of pre- and post-fault operational measures (from generation and network assets, e.g., reserves and phase shifters). In this manner, we can efficiently and securely deal with long term uncertainties (capacity and location of future generation) while meeting system security criteria. Flexible network investments are modeled since they can support integration of RES by alleviating network congestion pre- and post-fault and therefore reducing the need for new transmission lines.

Fig. 1 illustrates the five-level structure of the proposed methodology. In the first level, the min-max regret transmission plan is determined. In the second level, generation expansion realizes. In the third level, the pre-contingency schedule of power and reserves is determined considering the previously obtained transmission plan and the realized generation expansion (from first and second level). In the fourth level, any single outage or contingency realizes. Finally, in the fifth level the post-contingency schedule is determined.

III. MATHEMATICAL FORMULATION

The methodology proposed in this paper aims to determine the transmission expansion plan (comprising conventional and flexible transmission assets) under generation expansion un-

certainty while imposing deterministic security criterion. This objective is itself challenging since it involves the solution of a highly combinatorial problem. Hence, the representation of this problem in a single level formulation can become computationally intractable even for a system with a relatively small number of nodes. Therefore we present in this section a model decomposed in five levels in order to achieve our objectives with moderate computational effort.

The minimization of the maximum regret in the TEP problem under generation expansion uncertainty can be written as:

$$\text{Minimize } \text{MaxReg}(\mathbf{v}, \mathbf{f}^C) \quad (1)$$

$$(\mathbf{v}, \mathbf{f}^C) \in \mathcal{X}$$

subject to:

$$\text{MaxReg}(\mathbf{v}, \mathbf{f}^C) = \max_{s \in \Omega} \left\{ I(\mathbf{v}, \mathbf{f}^C) \right. \\ \left. + \sum_{t \in T} d_t \left[\min_{(\mathbf{p}, \mathbf{r}) \in \mathcal{P}(\mathbf{v}, \mathbf{f}^C, \mathbf{g}_{t,s})} \{ c^{op}(\mathbf{p}, \mathbf{r}) \} \right] - c_s^* \right\}, \quad (2)$$

where

$$\mathcal{X} = \left\{ \begin{array}{l} \mathbf{v} \in \{0, 1\}^{|\mathcal{L}^{PS} \cup \mathcal{L}^C|}, \quad \left| 0 \leq f_l^C \leq \bar{f}_l^C v_l; \right. \\ \mathbf{f}^C \in \mathbb{R}^{|\mathcal{L}^C|} \quad \left| \forall l \in \mathcal{L}^C \right. \end{array} \right\}.$$

In (1)–(2), the objective function to be minimized (1) is the maximum regret among all scenarios of future generation capacity. In our case, each scenario corresponds to a potential generation expansion plan, represented by vector $\mathbf{g}_{t,s}$, which captures the possible evolution pathways of RES capacity in the future. The total cost of each scenario represents the sum of investment and operation costs across all the operating conditions (or snapshots) that belong to set T , where duration of each snapshot d_t is specified (i.e., number of hours). The investment cost is given by $I(\mathbf{v}, \mathbf{f}^C)$, where \mathbf{v} is a vector of binary investment decision variables associated with new lines and phase shifters, and vector \mathbf{f}^C comprises the continuous decision variables associated with the capacity of new transmission lines. Similarly to [28] and [29], we represent the capacities of candidate lines as continuous decision variables. Nevertheless, it should be emphasized that, with very slight modification in the input data, our proposed methodology can also replicate the binary approach undertaken for transmission investment as in [2]–[5], [13], and [14], to mention a few. More specifically, in \mathcal{X} , the user can limit the value of each of these continuous decision variables related to capacity through adequate upper and lower capacity bounds which will be multiplied by the binary decision variable associated with line investment. In this manner, if the binary variable associated with a candidate line investment results equal to one (i.e., if the line is built), the capacity of this line will be equal to the bounded predefined value set in \mathcal{X} , following exactly the binary approach undertaken in [2]–[5], [13], and [14]. Hence, by choosing appropriate values of lower and upper bounds for line capacity, the user is able to decide whether newly built lines can have a single, fixed specific predefined capacity value or one that can be optimized within a range as a continuous decision variable. Sets \mathcal{L}^{PS} and \mathcal{L}^C refer to indexes of existing lines that are candidates for placement of phase shifters and new trans-

mission lines, respectively. The operation cost, $c^{op}(\mathbf{p}, \mathbf{r})$, is a function of the vectors \mathbf{p} and \mathbf{r} , which represent the power and spinning reserves scheduled, respectively across all possible operating points $\mathcal{P}(\mathbf{v}, \mathbf{f}^C, \mathbf{g}_{ts})$. The regret of a scenario is defined as the difference between (i) the cost (investment and operation) incurred in the decision obtained under uncertainty and (ii) the cost of the decision obtained under that particular scenario when assuming perfect information (i.e., full certainty about evolution of future generation capacity), given by c_s^* . Note that the $n - 1$ security criterion is enforced for both cases, namely uncertain future and perfect information. Hence, the maximum regret is the largest regret value among all considered scenarios, as defined in (2). It is important to highlight that the scenario that would lead to the maximum regret is not defined a priori, being decision-dependent and thus a result of the optimization.

Expression (2) can be rewritten as:

$$\text{MaxReg}(\mathbf{v}, \mathbf{f}^C) = \max_{s \in \Omega} \left\{ I(\mathbf{v}, \mathbf{f}^C) + \sum_{t \in T} d_t C_{ts}^O - c_s^* \right\}, \quad (3)$$

where

$$C_{ts}^O = \min_{(\mathbf{p}, \mathbf{r}) \in \mathcal{P}(\mathbf{v}, \mathbf{f}^C, \mathbf{g}_{ts})} \{c^{op}(\mathbf{p}, \mathbf{r})\}.$$

As discussed in [30] and [31], trilevel models are the most efficient manner to represent scheduling under security criteria. Following the findings of [31], the inner problem shown in (3) that schedules generation power outputs and reserves can be written as:

$$\begin{aligned} C_{ts}^O = & \underset{\substack{\Delta D_{bt}^{wc}, \theta_{bt}, \psi_{lt}, f_{lt}, \\ p_{it}, r_{it}^d, r_{it}^u}}{\text{Minimize}} \sum_{i \in I_w} C_i^S (\bar{W}_{its} - p_{it}) + \sum_{i \in I_c} C_i^P p_{it} \\ & + \sum_{i \in I_c} C_i^U r_{it}^u + \sum_{i \in I_c} C_i^D r_{it}^d + C^I \Delta D_{bt}^{wc} \end{aligned} \quad (4)$$

subject to:

$$\sum_{i \in I_b} p_{it} + \sum_{l \in \mathcal{L}|to(l)=b} f_{lt} - \sum_{l \in \mathcal{L}|fr(l)=b} f_{lt} = D_{bt}; \forall b \in N \quad (5)$$

$$f_{lt} = \frac{1}{x_l} (\theta_{fr(l),t} - \theta_{to(l),t}); \forall l \in \mathcal{L}^F \quad (6)$$

$$f_{lt} = \frac{1}{x_l} (\theta_{fr(l),t} - \theta_{to(l),t} + \psi_{lt}); \forall l \in \mathcal{L}^{PS} \quad (7)$$

$$\begin{aligned} -M_l(1 - v_l) \leq f_{lt} - \frac{1}{x_l} (\theta_{fr(l),t} - \theta_{to(l),t}) \\ \leq M_l(1 - v_l); (\rho_{lts}^+, \rho_{lts}^-); \forall l \in \mathcal{L}^C \end{aligned} \quad (8)$$

$$-v_l \bar{\psi} \leq \psi_{lt} \leq v_l \bar{\psi}; (\varphi_{lts}^+, \varphi_{lts}^-); \forall l \in \mathcal{L}^{PS} \quad (9)$$

$$-\bar{F}_l \leq f_{lt} \leq \bar{F}_l; \forall l \in (\mathcal{L}^F \cup \mathcal{L}^{PS}) \quad (10)$$

$$-f_l^C \leq f_{lt} \leq f_l^C; (\xi_{lts}^+, \xi_{lts}^-); \forall l \in \mathcal{L}^C \quad (11)$$

$$0 \leq p_{it} \leq \bar{P}_i; \forall i \in I_c \quad (12)$$

$$0 \leq p_{it} \leq \bar{W}_{its}; \forall i \in I_w \quad (13)$$

$$p_{it} + r_{it}^u \leq \bar{P}_i; \forall i \in I_c \quad (14)$$

$$p_{it} - r_{it}^d \geq 0; \forall i \in I_c \quad (15)$$

$$r_{it}^u \leq R_i^U; \forall i \in I_c \quad (16)$$

$$r_{it}^d \leq R_i^D; \forall i \in I_c \quad (17)$$

$$r_{it}^u = 0; \forall i \in I_w \quad (18)$$

$$r_{it}^d \leq p_{it}; \forall i \in I_w \quad (19)$$

$$\Delta D_{bt}^{wc} = \max_{\Delta_t, a_{it}^G, a_{it}^L} \left\{ \Delta_t \right\} \quad (20)$$

subject to:

$$\mathbf{f}(\{a_{it}^G\}_{i \in I}, \{a_{it}^L\}_{i \in \mathcal{L}}) \geq \mathbf{0} \quad (21)$$

$$a_{it}^G \in \{0, 1\}; \forall i \in I \quad (22)$$

$$a_{it}^L \in \{0, 1\}; \forall l \in \mathcal{L} \quad (23)$$

$$\Delta_t = \min_{\substack{\Delta D_{bt}^+, \Delta D_{bt}^-, \\ \theta_{bt}^{wc}, \psi_{lt}^{wc}, f_{lt}^{wc}, p_{it}^{wc}}} \left[\sum_{b \in N} (\Delta D_{bt}^+ + \Delta D_{bt}^-) \right] \quad (24)$$

subject to:

$$\begin{aligned} \sum_{i \in I_b} p_{it}^{wc} + \sum_{l \in \mathcal{L}|to(l)=b} f_{lt}^{wc} \\ - \sum_{l \in \mathcal{L}|fr(l)=b} f_{lt}^{wc} - \Delta D_{bt}^+ + \Delta D_{bt}^- \\ = D_{bt}; (\beta_{bt}); \forall b \in N \end{aligned} \quad (25)$$

$$f_{lt}^{wc} = \frac{a_{lt}^L}{x_l} (\theta_{fr(l),t}^{wc} - \theta_{to(l),t}^{wc}); (\omega_{lt}); \forall l \in \mathcal{L}^F \quad (26)$$

$$f_{lt}^{wc} = \frac{a_{lt}^L}{x_l} (\theta_{fr(l),t}^{wc} - \theta_{to(l),t}^{wc} + \psi_{lt}^{wc}); (\omega_{lt}); \forall l \in \mathcal{L}^{PS} \quad (27)$$

$$\begin{aligned} -M_l(1 - v_l a_{lt}^L) \leq f_{lt}^{wc} - \frac{1}{x_l} (\theta_{fr(l),t}^{wc} \\ - \theta_{to(l),t}^{wc}) \leq M_l(1 - v_l a_{lt}^L); (\sigma_{lt}^+, \sigma_{lt}^-); \\ \forall l \in \mathcal{L}^C \end{aligned} \quad (28)$$

$$\begin{aligned} -\bar{F}_l \leq f_{lt}^{wc} \leq \bar{F}_l; (\pi_{lt}^+, \pi_{lt}^-); \\ \forall l \in (\mathcal{L}^F \cup \mathcal{L}^{PS}) \end{aligned} \quad (29)$$

$$\begin{aligned} -a_{lt}^L f_l^C \leq f_{lt}^{wc} \leq a_{lt}^L f_l^C; (\chi_{lt}^+, \chi_{lt}^-); \\ \forall l \in \mathcal{L}^C \end{aligned} \quad (30)$$

$$a_{it}^G (p_{it} - r_{it}^d) \leq p_{it}^{wc} \leq a_{it}^G (p_{it} + r_{it}^u); (\gamma_{it}^+, \gamma_{it}^-); \forall i \in I \quad (31)$$

$$\begin{aligned} -v_l \bar{\psi} \leq \psi_{lt}^{wc} \leq v_l \bar{\psi}; (\eta_{lt}^+, \eta_{lt}^-); \\ \forall l \in \mathcal{L}^{PS} \end{aligned} \quad (32)$$

$$\left. \begin{aligned} \Delta D_{bt}^+, \Delta D_{bt}^- \geq 0; \forall b \in N \end{aligned} \right\} \quad (33)$$

Formulation (4)–(33) is a trilevel model, where the upper-level (4)–(19) refers to the pre-contingency generation dispatch of power and reserves. The decision variables of the upper-level are voltage angles, θ_{bt} , phase-shifting angles, ψ_{lt} , power flows, f_{lt} , power outputs, p_{it} , up- and down-spinning reserves, r_{it}^u and r_{it}^d , as well as the system power imbalance, ΔD_{bt}^{wc} . Coefficients C^S , C_i^P , C_i^U , C_i^D , and C^I represent cost of wind spillage, generation, up- and down-spinning reserves, and system power imbalance (which is penalized by a large number to avoid infeasible solutions), respectively. Parameters D_{bt} , M_l , x_l , $\bar{\psi}$, \bar{F}_l , \bar{P}_i , R_i^U , and R_i^D correspond to demand, sufficiently large constants (associated with the disjunctive approach, also used in [2] and [18]), reactances of lines, and capacity limits of phase shifters, transmission, generation and reserves, respectively, while \bar{W}_{its} represents the available capacity of renewable generator i at snapshot t in scenario s . Note that $\mathbf{g}_{ts} = [\bar{\mathbf{P}}^T | \mathbf{R}^{U^T} | \mathbf{R}^{D^T} | \mathbf{W}_{ts}^T]^T$. Sets I , I_w , I_c , I_b , N , \mathcal{L} , and \mathcal{L}^F include (in this order) all generating units, renewable generators, conventional power plants, generators attached to bus b , buses, all transmission lines, and existing transmission lines that cannot accommodate a new phase shifter. Dual variables ρ_{lts}^+ , ρ_{lts}^- , φ_{lts}^+ , φ_{lts}^- , ξ_{lts}^+ , and ξ_{lts}^- reflect the impact of the transmission plan on operating cost. The middle-level (20)–(23) is associated with the identification of the worst-case contingency state for the schedule determined in the pre-contingency state, and thus decision variables of the middle-level are the availability of generators, a_{it}^G , and lines, a_{lt}^L as well as the auxiliary variable Δ_t , which is an output of the lower-level problem. Finally, the lower-level (24)–(33) represents the system redispatch actions (or corrective actions) to deal with the worst-case contingency state, and thus decision variables of the lower-level are θ_{bt}^{wc} , ψ_{lt}^{wc} , f_{lt}^{wc} , and p_{it}^{wc} that represent post-contingency control of generation and network assets. ΔD_{bt}^+ and ΔD_{bt}^- are the nodal power violations. Note that dual variables are written within parenthesis after colons.

The objective function (4) of the upper-level formulation includes costs of wind spillage, generation, up- and down-spinning reserves as well as the system power imbalance cost. Constraints (5) refer to the nodal power balance. In a DC load flow fashion, constraints (6), (7), and (8) represent power transfers through existing lines, existing lines that are candidate to have a phase-shifter installed, and candidate lines to be built, respectively. Constraints (9) limit the control actions of phase shifters. Constraints (10) and (11) limit power transfers through existing and candidate lines, respectively. Similarly, capacities associated with generating units are enforced by (12) on existing units and by (13) on coming units under a given generation expansion scenario s . Limits to up- and down-spinning reserves are modeled by constraints (14)–(19).

The middle-level problem (20)–(23) finds the maximum system power imbalance associated with the pre-contingency schedule obtained by the upper-level. This is undertaken by optimizing vectors \mathbf{a}_t^G and \mathbf{a}_t^L , whose components indicate the availability of each element, e.g., a_{it}^G represents the availability of the generating unit i , i.e., it assumes a value equal to 1

if generator i is available and 0 otherwise. Likewise, a_{lt}^L is related to the availability of transmission line l . Constraint (21) ensures the prescribed levels of security, which can be written as $\sum_{i \in I} a_{it}^G + \sum_{l \in \mathcal{L}} a_{lt}^L \geq |I| + |\mathcal{L}| - 1$ for the $n - 1$ criterion. Constraints (22) and (23) describe the binary nature of vectors \mathbf{a}_t^G and \mathbf{a}_t^L .

The lower-level problem (24)–(33) describes the system response against the worst-case contingency identified by the middle-level. The objective function (24) represents the system power imbalance, which corresponds to the summation of nodal power violations (in absolute value), ΔD_{bt}^+ (generation curtailment) and ΔD_{bt}^- (demand curtailment), across all buses. Expressions (25)–(30) represent post-contingency network constraints. Constraints (31) impose the limits to generation redispatch actions according to the levels of power and reserves scheduled by the upper-level. Constraints (32) limit phase-shifting actions. Finally, constraints (33) ensure that ΔD_{bt}^+ and ΔD_{bt}^- are positive.

In summary, the model presented in this section is a 5-level optimization problem. The first level optimizes variables v_l and f_l^C , which are related to the transmission expansion plan. The second level identifies the generation expansion scenario (represented by \bar{W}_{its}) that leads to the maximum regret given the decided transmission plan. Once first and second level decisions are taken, v_l , f_l^C , and \bar{W}_{its} arrive as parameters for the trilevel model composed by third, fourth, and fifth levels. The purpose of this trilevel model is to assess the minimum operation cost of the system under a predefined deterministic security criterion given a transmission expansion (represented by v_l and f_l^C) and a generation expansion (represented by \bar{W}_{its}). To do so, a system dispatch (represented by θ_{bt} , ψ_{lt} , f_{lt} , p_{it} , r_{it}^d , and r_{it}^u) is decided in the third level so that any contingency (represented by a_{it}^G and a_{lt}^L) contained in the feasible region of the fourth level can be circumvented in the redispatch (represented by θ_{bt}^{wc} , ψ_{lt}^{wc} , f_{lt}^{wc} , and p_{it}^{wc}) of the fifth level.

IV. SOLUTION METHODOLOGY

The formulation shown through (1) and (3) corresponds to a MILP with five levels, where the first-level problem determines the transmission expansion plan, the second level problem identifies the scenario associated with the maximum regret, and the inner trilevel optimization model determines the system operation and its corresponding costs under each scenario of future installed generation capacity. In this section, we propose a procedure that iteratively identifies (for each snapshot of each scenario of generation expansion) the umbrella set of contingencies [32] and recasts the inner trilevel formulation (that determines system operation in each snapshot) to a linear program which is convex with respect to the main first-level decision. Due to the aforementioned convexity property, the operation cost can be approximated via cutting planes in a Benders-type outer algorithm. Next, we present in detail the proposed solution methodology.

A. Obtaining Operation Costs

Once a transmission expansion plan (defined by the vectors $\mathbf{v}^{(j)}$ and $\mathbf{f}^{C(j)}$) is proposed in iteration j of the outer algorithm, power and reserves in each period $t \in T$ and $s \in \Omega$ are scheduled in order to obtain $C_{ts}^{O(j)}$, $\forall t \in T, s \in \Omega$, i.e., the trilevel formulation (4)–(33) must be solved for all snapshots and scenarios. Hence we propose to solve the problem (4)–(33) through the solution methodology presented in [31], which presents the two following steps. Firstly, we develop a MILP associated with the middle- and lower-level operation models, hereinafter referred to as the oracle, to identify the worst-case contingency for a given set of power outputs and reserves scheduled. To do so, we replace the middle-level objective function by the dual representation of the lower-level objective function subject to the middle-level constraints and dual representation of the lower-level constraints, while linearizing some bilinear products. The formulation of the oracle is provided in the Appendix. Secondly, we formulate the following operation master problem.

$$C_{ts}^{O(j)} = \underset{\substack{\alpha_t, \Delta D_{bt}^{c+}, \Delta D_{bt}^{c-}, \\ \theta_{bt}, \theta_{bt}^c, \psi_{lt}, \psi_{lt}^c, \\ f_{lt}, f_{lt}^c, p_{it}, p_{it}^c, r_{it}^u, r_{it}^d}}{\text{Minimize}} \sum_{i \in I_w} C^S (\bar{W}_{its} - p_{it}) + \sum_{i \in I_c} C_i^P p_{it} + \sum_{i \in I_c} C_i^U r_{it}^u + \sum_{i \in I_c} C_i^D r_{it}^d + C^I \alpha_t \quad (34)$$

subject to:

$$\text{Constraints (5) – (19)} \quad (35)$$

$$\sum_{i \in I_b} p_{it}^c + \sum_{l \in \mathcal{L} | t_o(l)=b} f_{lt}^c - \sum_{l \in \mathcal{L} | f_r(l)=b} f_{lt}^c - \Delta D_{bt}^{c+} + \Delta D_{bt}^{c-} = D_{bt}; \forall b \in N, c \in \mathcal{C}^{(j)} \quad (36)$$

$$f_{lt}^c = \frac{a_{lt}^{L(c)}}{x_l} (\theta_{f_r(l),t}^c - \theta_{t_o(l),t}^c); \forall l \in \mathcal{L}^F, c \in \mathcal{C}^{(j)} \quad (37)$$

$$f_{lt}^c = \frac{a_{lt}^{L(c)}}{x_l} (\theta_{f_r(l),t}^c - \theta_{t_o(l),t}^c + \psi_{lt}^c); \forall l \in \mathcal{L}^{PS}, c \in \mathcal{C}^{(j)} \quad (38)$$

$$-M_l(1 - v_l^{(j)}) \leq f_{lt}^c - \frac{a_{lt}^{L(c)}}{x_l} (\theta_{f_r(l),t}^c - \theta_{t_o(l),t}^c) \leq M_l(1 - v_l^{(j)}); (\rho_{lts}^{c+(j)}, \rho_{lts}^{c-(j)}); \forall l \in \mathcal{L}^C, c \in \mathcal{C}^{(j)} \quad (39)$$

$$-\bar{F}_l \leq f_{lt}^c \leq \bar{F}_l; \forall l \in (\mathcal{L}^F \cup \mathcal{L}^{PS}), c \in \mathcal{C}^{(j)} \quad (40)$$

$$-f_l^{C(j)} \leq f_{lt}^c \leq f_l^{C(j)}; (\xi_{lts}^{c+(j)}, \xi_{lts}^{c-(j)}); \forall l \in \mathcal{L}^C, c \in \mathcal{C}^{(j)} \quad (41)$$

$$a_{it}^{G(c)}(p_{it} - r_{it}^d) \leq p_{it} \leq a_{it}^{G(c)}(p_{it} + r_{it}^u); \forall i \in I, c \in \mathcal{C}^{(j)} \quad (42)$$

$$-v_l^{(j)}\bar{\psi} \leq \psi_{lt}^c \leq v_l^{(j)}\bar{\psi}; (\varphi_{lts}^{c+(j)}, \varphi_{lts}^{c-(j)}); \forall l \in \mathcal{L}^{PS}, c \in \mathcal{C}^{(j)} \quad (43)$$

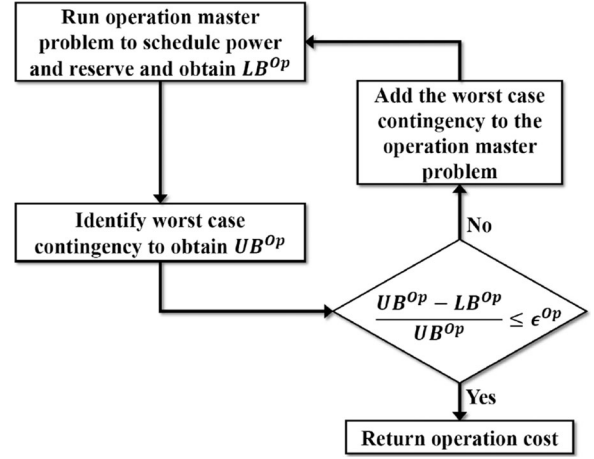

Fig. 2. Procedure to obtain operation cost for each snapshot.

$$\alpha_t \geq \sum_{b \in N} \left[\Delta D_{bt}^{c+} + \Delta D_{bt}^{c-} \right]; c \in \mathcal{C}^{(j)} \quad (44)$$

$$\Delta D_{bt}^{c+}, \Delta D_{bt}^{c-} \geq 0; \forall b \in N, c \in \mathcal{C}^{(j)}. \quad (45)$$

The formulation (34)–(45) is a relaxation of (4)–(33) since it only comprises a subset of the contingency set associated with the security criterion imposed in (21). Nevertheless, (34)–(45) and (4)–(33) provide equivalent results of operation cost as well as power and reserves schedule when $\mathcal{C}^{(j)}$ includes the umbrella contingency set, which is the set with the smallest number of contingencies capable to preserve the feasible region.

As depicted in Fig. 2, in the first iteration of the algorithm to obtain the operation cost, we solve model (34)–(35) since the set of contingencies $\mathcal{C}^{(j)}$ begins empty. Once the worst-contingency for the proposed schedule of power and reserves is identified, a convergence test is performed. If convergence is not achieved, the contingency c identified is included in $\mathcal{C}^{(j)}$. Therefore, in the next iteration of the algorithm to obtain the operation cost, new variables ΔD_{bt}^{c+} , ΔD_{bt}^{c-} , θ_{bt}^c , ψ_{lt}^c , f_{lt}^c , and p_{it}^c are included. The inclusion of these new variables generates new columns in (34)–(45). In addition, in order to describe the feasible region for the newly added variables, a new block of expressions (36)–(45) is included and this inclusion generates new constraints. The model (34)–(45) is then solved again and new contingencies c are iteratively included in set $\mathcal{C}^{(j)}$ (therefore new columns and constraints are included) until convergence is achieved. Thus, the solution algorithm associated with the operation model is the following:

- 1) Solve the optimization model (34)–(45) with $\mathcal{C}^{(j)} = \emptyset$, store \mathbf{p}_t as well as \mathbf{r}_t , and calculate $LB^{Op} = \sum_{i \in I_w} C^S (\bar{W}_{its} - p_{it}) + \sum_{i \in I_c} C_i^P p_{it} + \sum_{i \in I_c} C_i^U r_{it}^u + \sum_{i \in I_c} C_i^D r_{it}^d$.
- 2) Identify the worst-case contingency for stored \mathbf{p}_t and \mathbf{r}_t by running the oracle and calculate $UB^{Op} = \sum_{i \in I_w} C^S (\bar{W}_{its} - p_{it}) + \sum_{i \in I_c} C_i^P p_{it} +$

$\sum_{i \in I_c} C_i^U r_{it}^u + \sum_{i \in I_c} C_i^D r_{it}^d + C^I \Delta D_t^{wc}$, where ΔD_t^{wc} is the worst-case system power imbalance determined by the oracle.

- 3) If $(UB^{Op} - LB^{Op})/UB^{Op} \leq \epsilon^{Op}$, then STOP and return C_{ts}^O ; else, CONTINUE.
- 4) Include the worst-case contingency identified by the oracle in $\mathcal{C}^{(j)}$ (this generates new columns and constraints in the master problem).
- 5) Solve the optimization model (34)–(45), store \mathbf{p}_t as well as \mathbf{r}_t , calculate $LB^{Op} = \sum_{i \in I_w} C^S (\bar{W}_{its} - p_{it}) + \sum_{i \in I_c} C_i^P p_{it} + \sum_{i \in I_c} C_i^U r_{it}^u + \sum_{i \in I_c} C_i^D r_{it}^d + C^I \alpha_t$, and go to step 2.

B. Obtaining Transmission Expansion Plan

The formulation (34)–(45) is a linear program where the right hand side is parameterized through vectors $\mathbf{f}^{C(j)}$ and $\mathbf{v}^{(j)}$, and therefore the operation cost $C_{ts}^{O(j)}$ is a convex function of the transmission expansion plan which can be approximated via cutting planes at each iteration j . Hence we propose a Benders-type solution algorithm that iteratively calculates lower and upper bounds for the minimum maximum regret and finitely converges to the optimal solution.

A lower bound can be calculated for the minimum maximum regret at iteration j by solving the following model:

$$LB^{Reg(j)} = \underset{\delta_{ts}, (\mathbf{v}, \mathbf{f}^c) \in \mathcal{X}, MaxRegret}{\text{Minimize}} \quad MaxRegret \quad (46)$$

subject to:

$$MaxRegret \geq I(\mathbf{v}, \mathbf{f}^c) + \sum_{t \in T} d_t \delta_{ts} - c_s^*; \forall s \in \Omega \quad (47)$$

$$\begin{aligned} \delta_{ts} \geq & C_{ts}^{O(m)} + \sum_{l \in \mathcal{L}^C} (v_l - v_l^{(m)}) M_l \left[\rho_{lts}^{+(m)} + \rho_{lts}^{-(m)} \right. \\ & + \sum_{c \in \mathcal{C}^{(m)}} \left(\rho_{lts}^{c+(m)} + \rho_{lts}^{c-(m)} \right) \left. \right] + \sum_{l \in \mathcal{L}^{PS}} (v_l - v_l^{(m)}) \bar{\psi} \left[-\varphi_{lts}^{+(m)} \right. \\ & - \varphi_{lts}^{-(m)} - \sum_{c \in \mathcal{C}^{(m)}} \left(\varphi_{lts}^{c+(m)} + \varphi_{lts}^{c-(m)} \right) \left. \right] + \sum_{l \in \mathcal{L}^C} (f_l^C \\ & - f_l^{C(m)}) \left[-\xi_{lts}^{+(m)} - \xi_{lts}^{-(m)} - \sum_{c \in \mathcal{C}^{(m)}} \left(\xi_{lts}^{c+(m)} + \xi_{lts}^{c-(m)} \right) \right]; \end{aligned} \quad (48)$$

$$\forall t \in T, s \in \Omega, m = 1, \dots, j-1 \quad (48)$$

$$\delta_{ts} \geq 0; \forall t \in T, s \in \Omega, \quad (49)$$

where the objective function (46) is identical to (1), constraints (47) correspond to (3) where δ_{ts} is the approximation of the operation costs per snapshot and scenario via cutting planes shown in (48) in terms of the dual variables obtained from (34)–(45). Finally, constraints (49) ensure that δ_{ts} is non-negative. On the other hand, an upper bound to the minimum maximum

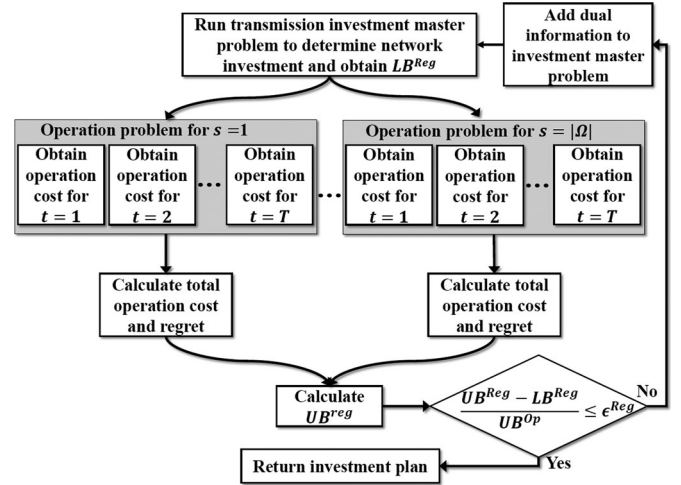

Fig. 3. Solution algorithm to determine the optimal transmission plan.

regret can be obtained as follows:

$$UB^{Reg(j)} = \max_{s \in \Omega} \left\{ I(\mathbf{v}^{(j)}, \mathbf{f}^{C(j)}) + \sum_{t \in T} d_t C_{ts}^{O(j)} - c_s^* \right\}. \quad (50)$$

The steps of the proposed solution algorithm, as depicted in Fig. 3, can be summarized as follows:

- 1) *Initialization*: Set the iteration counter: $j \leftarrow 0$.
- 2) Solve the optimization model defined by (46), (47), and (49), store $\mathbf{v}^{(j)}$, $\mathbf{f}^{C(j)}$, and $LB^{Reg(j)}$.
- 3) Obtain $C_{ts}^{O(j)} \forall t \in T, s \in \Omega$ by running the procedure described in Section IV-A. Calculate $UB^{Reg(j)}$ through (50) and store it.
- 4) If $(UB^{Reg(j)} - LB^{Reg(j)})/UB^{Reg(j)} \leq \epsilon^{Reg}$, then STOP and return the transmission plan; else, CONTINUE.
- 5) Update the iteration counter: $j \leftarrow j + 1$.
- 6) Solve the optimization model defined by (46)–(49), store $\mathbf{v}^{(j)}$, $\mathbf{f}^{C(j)}$, and $LB^{Reg(j)}$. Go to step 3.

It should be emphasized that not only the so-called worst contingency is comprised but all credible contingencies (in the case of $n-1$ security, all single outages) are taken into account. As illustrated in Fig. 3, once a transmission plan is proposed by the master problem, the operation cost under each scenario of generation expansion is evaluated in order to compute the upper bound for the maximum regret. This operation cost, as customary in power systems operation, comprises the cost to provide security of supply under contingencies of system elements. In order to efficiently comprise these contingencies, instead of explicitly and exhaustively representing all of them by means of constraints in the operation problem, we just represent a subset of contingencies that includes the umbrella set of contingencies (which is the set of contingencies that needs to have null imbalance imposed so that all the other considered contingencies will also lead to null imbalance). This subset of contingencies is built by identifying the worst-case contingency for each proposed power and reserves dispatch at each iteration of the algorithm that minimizes the operation cost (see Fig. 2).

Clearly, each dispatch may have a different worst-case contingency. Within this framework, since the goal at this point is to identify the least expensive dispatch and system power imbalance is highly penalized, the system power imbalance will be minimized as much as possible. If it is not possible to avoid system power imbalance for a particular scenario, the operation cost of such scenario will be very high as well as its corresponding regret. Therefore, in the next iteration of the algorithm that determines the expansion plan, given the additional dual information, the master problem will naturally select a transmission plan that provides the system with necessary leeway to circumvent the system power imbalance recognized in the previous iteration. Finally, deliverability of reserves is guaranteed since post-contingency constraints are imposed in the fifth level of the formulation.

V. CASE STUDIES

In this section, the key objectives of the studies carried out are: (i) validate the model, (ii) analyze the results and the main features of transmission plans against various sources of uncertainty, and finally (iii) examine the computational performance and scalability of the proposed solution algorithm. In order to achieve this, we use a tailor-made 6-bus system and the standard IEEE 118-bus system whose data can be found in [33]. In the presented case studies, we use a linear investment cost function of the form $I(\mathbf{v}, \mathbf{f}^C) = \sum_{l \in (\mathcal{L}^C \cup \mathcal{L}^{Ps})} C_l^{fix} v_l + \sum_{l \in \mathcal{L}^C} C_l^{Cap} f_l^C$, where C_l^{fix} and C_l^{Cap} are annual fixed investment cost to install a candidate transmission asset l and annual investment cost of transmission capacity of a candidate transmission line l , respectively. The proposed methodology has been implemented in a computer with two Intel Xeon E5-2697 v2 processors (2.7 GHz) and 512 GB of RAM, using Xpress-MP 7.8 [34].

A. 6-Bus System

As shown in Fig. 4, this system is composed of four existing buses and two potential new buses where wind generation might be connected in the future. In addition, there are three existing lines and six candidate lines. We also consider two candidate phase shifters (in lines L2 and L3) that can be installed to provide flexibility to network investment options and thus deal with uncertainty from generation expansion and outages more efficiently. To analyze the effects of security of supply, we obtain transmission expansion plans with and without $n - 1$ security criterion. We also study the savings achieved when phase shifters are applied. In addition, we compare the min-max regret solution against plans that assume perfect information about future generation installed capacity. For this case study, we have set convergence tolerance parameters ϵ^{Op} and ϵ^{Reg} equal to 10^{-3} . The branch and bound relative gap to solve MILP problems at each iteration was set equal to 10^{-4} . For the case without security criterion, 12 iterations of the algorithm (illustrated in Fig. 3) were required. In each iteration (except the last one when convergence is achieved) the number of cutting

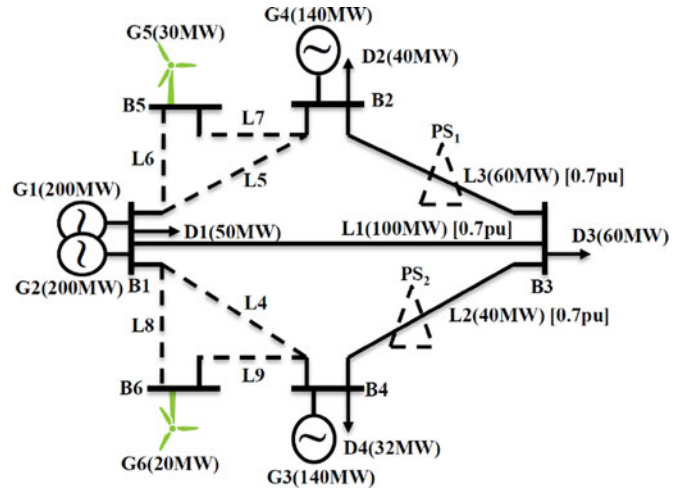

Fig. 4. Generation, network, and demand data of 6-Bus system, where continuous lines refer to existing infrastructure and dashed lines refer to candidate infrastructure. Normal brackets refer to generation and network capacities and peak demand conditions, while square brackets refer to reactances.

planes added to the transmission investment master problem is equal to the number of snapshots multiplied by the number of scenarios. Therefore, 132 cutting planes were included in the block of constraints (48) in this case. For the case with $n - 1$ security criterion and with candidate phase shifters, 21 iterations were needed. Consequently, 240 cutting planes were added to the master in this case. Finally, for the case with $n - 1$ security criterion and without candidate phase shifters, 26 iterations were required, resulting in the inclusion of 300 cutting planes.

There are four scenarios (S1, S2, S3, and S4) under consideration to represent uncertainty in future wind generation capacity. In S1, no generator is built/realized. In S2, generator G5 is built. In S3, generator G6 is built. Finally, in S4, generation expansion includes realization of both G5 and G6. Each scenario consists of three snapshots (each of 2920 hours) which represent combinations of demand and wind power outputs that may occur during a year.

Table I presents the cost associated with the solution under perfect information and the regret associated with the min-max regret (MMR) solution in each scenario, which is obtained when facing uncertainty in the forthcoming generation expansion. In addition, Table II displays expansion plans (i) without security criterion, (ii) with $n - 1$ security criterion and no candidate phase shifters, and (iii) with both $n - 1$ criterion and candidate phase shifters. We can observe that, when the security requirement is imposed, more transmission assets are built. In addition, note that, when the $n - 1$ security criterion is imposed, expansion plans are more prone to install phase shifters (see L3 in S1 and S2) and this is exacerbated in the min-max regret solution under uncertainty when two phase shifters are installed. This demonstrates that increased levels of flexibility are needed to deal with high levels of uncertainty. Furthermore, holding levels of spinning reserves needed to deal with security provision against single outages is reduced in the case where phase shifters

TABLE I
6-BUS SYSTEM – COSTS OF ALTERNATIVE EXPANSION PLANS UNDER PERFECT INFORMATION AND UNDER UNCERTAINTY (MMR SOLUTION)
AND REGRETS OF THE MMR SOLUTION UNDER EACH SCENARIO

			Scenario 1	Scenario 2	Scenario 3	Scenario 4
Without security criterion	Under Perfect Information about future generation capacity	Total Cost (M\$/year)	12.48	11.09	11.62	10.10
		Operation Cost (M\$/year)	11.56	10.55	10.54	9.02
		Investment Cost (M\$/year)	0.92	0.54	1.08	1.08
	Under Uncertainty in future generation capacity (MMR solution)	Total Cost (M\$/year)	13.19	11.80	12.32	10.81
		Operation Cost (M\$/year)	11.56	10.17	10.69	9.18
		Investment Cost (M\$/year)	1.63	1.63	1.63	1.63
		Regret of MMR solution (M\$/year)	0.71	0.71	0.70	0.71
With $n - 1$ security criterion (with candidate phase shifters)	Under Perfect Information about future generation capacity	Total Cost (M\$/year)	17.25	15.79	16.09	14.63
		Operation Cost (M\$/year)	15.03	13.06	13.70	11.73
		Investment Cost (M\$/year)	2.22	2.73	2.39	2.90
	Under Uncertainty in future generation capacity (MMR solution)	Total Cost (M\$/year)	17.97	16.00	16.65	14.67
		Operation Cost (M\$/year)	15.03	13.06	13.71	11.73
		Investment Cost (M\$/year)	2.94	2.94	2.94	2.94
		Regret of MMR solution (M\$/year)	0.72	0.21	0.56	0.04
With $n - 1$ security criterion (without candidate phase shifters)	Under Perfect Information about future generation capacity	Total Cost (M\$/year)	17.96	16.40	16.09	14.63
		Operation Cost (M\$/year)	15.04	13.31	13.70	11.73
		Investment Cost (M\$/year)	2.92	3.09	2.39	2.90
	Under Uncertainty in future generation capacity (MMR solution)	Total Cost (M\$/year)	18.94	17.03	17.16	15.70
		Operation Cost (M\$/year)	15.48	13.57	13.70	12.24
		Investment Cost (M\$/year)	3.46	3.46	3.46	3.46
		Regret of MMR solution (M\$/year)	0.98	0.63	1.07	1.07

are installed. On the contrary, preventing installation of flexible devices drives more transmission redundancy for the provision of security, increasing investment costs. Therefore, overall costs (investment plus operation) and regrets can be reduced by allowing investments in phase shifters that can efficiently provide flexibility to deal with short- and long-term uncertainties.

Table III shows a comparison between the proposed methodology and a heuristic procedure typically applied in the power industry. This heuristic method identifies the transmission plan that minimizes the maximum regret among the investment options found under perfect information [26], [35]. As Table III shows, both costs and regrets associated with this method are significantly larger than those obtained by the proposed model,

since the latter appropriately captures the uncertainties under consideration when determining the transmission investment. Clearly, when uncertainty is formally considered, a different solution to any of those obtained under perfect information may emerge. This demonstrates that flexible investment solutions against uncertainty include investment options that are not possible to observe in the solutions obtained under perfect information, which ultimately underestimate the value of flexibility and robustness. In contrast, investment options determined by the min-max regret problem adequately value flexibility levels that are needed to hedge against various potential future scenarios of generation expansion and outages. Hence it is important to recognize that current planning approaches adopted

TABLE II
6-BUS SYSTEM – NEW INFRASTRUCTURE OF ALTERNATIVE EXPANSION PLANS. DECISIONS UNDER PERFECT INFORMATION (S1,S2,S3,S4) AND UNDER UNCERTAINTY (MMR).

Assumption	Case	Decision
<i>n</i> – 0 with candidate PS	S1	L4(48 MW)
	S2	L7(30 MW)
	S3	L8(20 MW), L9(40 MW)
	S4	L7(30 MW), L9(20 MW)
	MMR	L6(35 MW), L7(43 MW), L9(15 MW)
<i>n</i> – 1 with candidate PS	S1	L3(PS), L4(42 MW), L5(90 MW)
	S2	L3(PS), L4(32 MW), L5(70 MW), L7(30 MW)
	S3	L4(50 MW), L5(62 MW), L9(20 MW)
	S4	L4(41 MW), L5(41 MW), L7(30 MW), L9(20 MW)
	MMR	L2(PS), L3(PS), L6(96 MW), L7(96 MW), L8(36 MW), L9(36 MW)
<i>n</i> – 1 without candidate PS	S1	L4(48 MW), L5(61 MW), L8(24 MW), L9(24 MW)
	S2	L5(51 MW), L6(13 MW), L7(40 MW), L8(40 MW), L9(40 MW)
	S3	L4(50 MW), L5(62 MW), L9(20 MW)
	S4	L4(41 MW), L5(41 MW), L7(30 MW), L9(20 MW)
	MMR	L4(47 MW), L5(59 MW), L6(17 MW), L8(24 MW), L9(24 MW)

TABLE III
6-BUS SYSTEM – OVERALL COSTS AND REGRETS PER SCENARIO (IN M\$/YEAR) OF IMPLEMENTING DECISIONS UNDER PERFECT INFORMATION (S1, S2, S3 AND S4) AND UNDER UNCERTAINTY (MMR). COSTS AND REGRETS ARE INDICATED WITHOUT AND WITHIN BRACKETS, RESPECTIVELY.

Decision	Realization			
	S1	S2	S3	S4
S1	17.25 (0.00)	17.40 (1.61)	17.35 (1.26)	17.50 (2.87)
S2	25.04 (7.79)	15.79 (0.00)	25.14 (9.05)	15.89 (1.26)
S3	22.35 (5.10)	22.50 (6.71)	16.09 (0.00)	16.24 (1.61)
S4	34.90 (17.65)	22.02 (6.23)	27.01 (10.92)	14.63 (0.00)
MMR	17.97 (0.72)	16.00 (0.21)	16.65 (0.56)	14.67 (0.04)

in the power industry may neglect network investments that are only valuable to deal with uncertainty and may underestimate the value of technologies such as FACTS to efficiently provide flexibility and robustness to transmission plans and this is critical in the light of increasing uncertainty levels that characterize future generation deployments.

B. IEEE 118-Bus System

This case study illustrates the scalability of the proposed methodology to a larger network based on the IEEE 118-Bus System, which comprises 118 buses, 181 existing transmission lines, 23 candidate transmission assets (7 candidate phase shifters and 16 candidate lines), 54 conventional generators, and 4 potential new renewable units to be located in buses 101, 109, 113, and 115. We consider 7 scenarios of future generation capacity expansion. S1, S2, S3, and S4 involve the construc-

TABLE IV
118-BUS SYSTEM – NEW INFRASTRUCTURE OF ALTERNATIVE EXPANSION PLANS (NO SECURITY) AND THE ASSOCIATED COMPUTING TIME. DECISIONS UNDER PERFECT INFORMATION (S1, S2,...,S7) AND UNDER UNCERTAINTY (MMR).

Case	Decision	Computing Time(s)
S1	32-113(100 MW)	9.86
S2	114-115(50 MW)	9.52
S3	109-110(100 MW)	12.55
S4	100-101(100 MW)	12.26
S5	17-113(100 MW), 114-115(50 MW)	12.35
S6	108-109(100 MW), 101-102(100 MW)	13.66
S7	17-113(100 MW), 114-115(50 MW), 109-110(100 MW), 100-101(100 MW)	14.75
MMR	32-113(100 MW), 114-115(50 MW), 108-109(100 MW), 100-101(100 MW)	74.08

tion of new generating units in bus 113, 115, 109, and 101, respectively. In S5, generators in buses 113 and 115 are built, while in S6, generators in buses 109 and 101 are built. In S7, all new generating units are built. For this case study, we have set convergence tolerance parameters ϵ^{Op} and ϵ^{Reg} equal to 5×10^{-3} and 10^{-2} , respectively. The branch and bound relative gap to solve MILP problems at each iteration was set equal to 10^{-4} . For the case without security criterion, convergence of the algorithm (illustrated in Fig. 3) was achieved in 9 iterations. Therefore, 168 cutting planes were included in the transmission investment master. For the case with *n* – 1 security criterion, 45 iterations were required. Consequently, 924 cutting planes were added to the master in this case.

Tables IV, V, and VI present the results that demonstrate the need for further transmission assets to provide security of supply and the need for further investment options to deal with uncertainty (which are not revealed in the solutions under perfect information). For the sake of comparison, we developed an equivalent single-level MILP that explicitly enumerates all scenarios and contingencies to obtain the same min-max regret solutions reported in Table V. Although this model could be used to obtain investment plans without security criterion, no feasible solution was found (after a week) when *n* – 1 criterion is imposed. The proposed methodology, instead, can effectively find the min-max regret solution under *n* – 1 criterion for all tested cases as reported in Table VI.

Finally, we performed an out of sample contingency analysis in order to compare the performance of the solutions with and without security criterion (*n* – 1). This comparison is in terms of reliability. Thus, we generated via Monte Carlo simulation 10,000 contingency states for each snapshot of each possible scenario of future generation capacity. Each contingency state was generated by simulating independent Bernoulli trials for the availability of each line and generator state (1 for available and 0 for unavailable state). As in [36], we set to 0.1% and 1% the probability of outage for lines and generators, respectively. For each simulated contingency state, we assessed the system

TABLE V
118-BUS SYSTEM – COSTS OF ALTERNATIVE EXPANSION PLANS UNDER PERFECT INFORMATION AND UNDER UNCERTAINTY (MMR SOLUTION)
AND REGRETS OF THE MMR SOLUTION UNDER EACH SCENARIO

			Scenario 1	Scenario 2	Scenario 3	Scenario 4	Scenario 5	Scenario 6	Scenario 7
Without security criterion	Under Perfect Information about future generation capacity	Total Cost (M\$/year)	80.29	82.34	80.39	80.38	85.29	83.29	92.17
		Operation Cost (M\$/year)	71.51	73.64	71.61	71.60	67.81	65.72	57.12
		Investment Cost (M\$/year)	8.78	8.70	8.78	8.78	17.48	17.57	35.05
	Under Uncertainty in future generation capacity (MMR solution)	Total Cost (M\$/year)	106.64	108.69	106.74	106.73	104.57	100.94	93.33
		Operation Cost (M\$/year)	71.59	73.64	71.69	71.68	69.52	65.89	58.28
		Investment Cost (M\$/year)	35.05	35.05	35.05	35.05	35.05	35.05	35.05
Regret of MMR solution (M\$/year)		26.35	26.35	26.35	26.35	19.28	17.65	1.16	
With $n - 1$ security criterion	Under Perfect Information about future generation capacity	Total Cost (M\$/year)	125.60	110.41	125.61	125.56	110.36	125.97	114.29
		Operation Cost (M\$/year)	96.36	98.67	96.37	96.32	89.76	87.93	76.19
		Investment Cost (M\$/year)	29.24	11.74	29.24	29.24	20.60	38.03	38.10
	Under Uncertainty in future generation capacity (MMR solution)	Total Cost (M\$/year)	152.75	147.54	162.56	146.50	147.50	156.32	151.41
		Operation Cost (M\$/year)	103.78	98.57	113.59	97.53	98.53	107.35	102.44
		Investment Cost (M\$/year)	48.97	48.97	48.97	48.97	48.97	48.97	48.97
Regret of MMR solution (M\$/year)		27.15	37.13	36.95	20.94	37.14	30.35	37.12	

TABLE VI

118-BUS SYSTEM – NEW INFRASTRUCTURE OF ALTERNATIVE EXPANSION PLANS (With $n - 1$ SECURITY) AND THE ASSOCIATED COMPUTING TIME. DECISIONS UNDER PERFECT INFORMATION (S1, S2,...,S7) AND UNDER UNCERTAINTY (MMR).

Case	Decision	Computing Time(s)
S1	31-32(PS), 11-117(13 MW), 17-113(100 MW), 27-114(50 MW)	9948.05
S2	11-117(11 MW), 114-115(50 MW)	3880.77
S3	31-32(PS), 11-117(14 MW), 27-114(50 MW), 109-110(100 MW)	10499.80
S4	31-32(PS), 11-117(12 MW), 27-114(50 MW), 100-101(100 MW)	11295.50
S5	11-117(18 MW), 17-113(141 MW), 114-115(50 MW)	3832.68
S6	31-32(PS), 11-117(30 MW), 27-114(50 MW), 109-110(100 MW), 101-102(100 MW)	9607.17
S7	11-117(17 MW), 17-113(100 MW), 114-115(50 MW), 108-109(100 MW), 100-101(100 MW)	6361.07
MMR	31-32(PS), 11-117(21 MW), 32-113(98 MW), 27-115(50 MW), 114-115(100 MW), 108-109(94 MW), 101-102(100 MW)	45314.70

imbalance for (i) the min-max regret transmission plan that was obtained without imposing security criterion and for (ii) the min-max regret transmission plan that was obtained while imposing the $n - 1$ security criterion. Tables VII and VIII summarize the results of this experiment. As can be seen from these results,

TABLE VII

RESULTS OF THE CONTINGENCY ANALYSIS FOR THE MMR TRANSMISSION PLAN WITHOUT SECURITY CRITERION

Scenario	Probability of Imbalance (%)	Exp. Value of Imbalance (% of demand)	CVaR of Imbalance (% of demand)
S1	8.08%	1.19%	21.96%
S2	7.84%	1.26%	23.62%
S3	7.30%	1.13%	21.20%
S4	7.20%	1.10%	20.82%
S5	8.61%	1.16%	21.48%
S6	8.30%	1.14%	20.83%
S7	9.81%	1.10%	18.51%

TABLE VIII

RESULTS OF THE CONTINGENCY ANALYSIS FOR THE MMR TRANSMISSION PLAN WITH $n - 1$ SECURITY CRITERION

Scenario	Probability of Imbalance (%)	Exp. Value of Imbalance (% of demand)	CVaR of Imbalance (% of demand)
S1	0.45%	0.03%	0.68%
S2	0.47%	0.03%	0.60%
S3	0.33%	0.02%	0.46%
S4	0.35%	0.03%	0.63%
S5	0.42%	0.03%	0.51%
S6	0.42%	0.03%	0.60%
S7	0.46%	0.03%	0.53%

by considering a security criterion while planning the system expansion, we are able to dramatically decrease levels of probability of system imbalance, expected value of system imbalance, and CVaR (with 95% confidence) of system imbalance.

VI. CONCLUSIONS

This paper proposed a novel methodology to determine optimal transmission expansion plans through a min-max regret approach. A 5-level model is formulated to determine the transmission plan that leads to the minimum maximum regret under uncertainty in future generation expansion. The proposed formulation also considers occurrence of system outages, securing operation through a deterministic $n - 1$ criterion. Candidate infrastructure includes flexible and conventional transmission assets and hence the model can determine optimal portfolios of phase shifters and transmission lines to deal with both long- and short-term uncertainties. To solve the optimization problem, we developed an algorithm based on column and constraint generation and Benders decomposition techniques to determine the optimal solution of the proposed 5-level model in a finite number of iterations.

Numerical studies demonstrated that the value of flexible network technologies increases with explicit recognition of uncertainty, and that flexible network portfolios can effectively reduce the regret of investment decisions and improve economic efficiency and security of supply provision. Furthermore, we also demonstrated that there are specific investment decisions which are revealed only when uncertainty is explicitly modeled and that flexible transmission investment options may remain unseen when network infrastructure is planned through considering deterministic scenarios.

As customary in TEP models, we simplified the power flow by adopting a DC load fashion. Further research will consider including AC transmission constraints in our proposed framework as well as inter-temporal connection between the snapshots of operation.

Finally, we have used a discrete set of scenarios to represent generation expansion uncertainty following industry practices. It is a plausible and reasonable alternative for this kind of uncertainty since it provides industry players, regulators, planners and further stakeholders with the possibility to express their views about uncertainty in generation expansion. This uncertainty is mainly driven by generation companies' investment decisions and thereby significantly affected by policy, political and further macroeconomic conditions that are difficult to model in a real context. Our proposed methodology is therefore highly dependent on the quality of the provided scenarios, which require significant time and effort to be generated since they must properly characterize the set of economic and political structures of possible futures. In addition, we recognize that it would be interesting to consider, within the proposed framework, stress-test scenarios as those generated by the combinations of up/down deviations within a constrained uncertainty budget. This consideration can open up interesting opportunities for future research.

APPENDIX

The oracle mentioned in Section IV-A is formulated as follows:

$$\Delta D_t^{wc} = \underset{\substack{\beta_{bt}, \gamma_{it}^+, \gamma_{it}^-, \\ \eta_{it}^+, \eta_{it}^-, \pi_{it}^+, \pi_{it}^-, \\ \sigma_{it}^+, \sigma_{it}^-, \chi_{it}^+, \chi_{it}^-, \omega_{it}}}{\text{Maximize}} \sum_{b \in N} D_{bt} \beta_{bt}$$

$$\begin{aligned} & - \sum_{l \in \mathcal{L}^C} (1 - a_{lt}^L v_l) M_l \sigma_{lt}^+ - \sum_{l \in \mathcal{L}^C} (1 - a_{lt}^L v_l) M_l \sigma_{lt}^- \\ & - \sum_{l \in (\mathcal{L}^F \cup \mathcal{L}^{PS})} \bar{F}_l \pi_{lt}^+ - \sum_{l \in (\mathcal{L}^F \cup \mathcal{L}^{PS})} \bar{F}_l \pi_{lt}^- \\ & - \sum_{l \in \mathcal{L}^C} a_{lt}^L f_l^C \chi_{lt}^+ - \sum_{l \in \mathcal{L}^C} a_{lt}^L f_l^C \chi_{lt}^- \\ & + \sum_{l \in I} a_{it}^G (p_{it} - r_{it}^d) \gamma_{it}^+ - \sum_{l \in I} a_{it}^G (p_{it} + r_{it}^u) \gamma_{it}^- \\ & - \sum_{l \in \mathcal{L}^{PS}} v_l \bar{\psi} \eta_{lt}^+ - \sum_{l \in \mathcal{L}^{PS}} v_l \bar{\psi} \eta_{lt}^- \end{aligned} \quad (51)$$

subject to:

$$\text{Constraints (21) - (23)} \quad (52)$$

$$\beta_{bt} + \gamma_{it}^+ - \gamma_{it}^- \leq 0 : (p_{it}^{wc}); \forall b \in N, i \in I \quad (53)$$

$$\beta_{to(l),t} - \beta_{fr(l),t} + \omega_{lt} + \pi_{lt}^+ - \pi_{lt}^- = 0 : (f_{lt}^{wc}); \quad \forall l \in (\mathcal{L}^F \cup \mathcal{L}^{PS}) \quad (54)$$

$$\beta_{to(l),t} - \beta_{fr(l),t} + \sigma_{lt}^+ - \sigma_{lt}^- + \chi_{lt}^+ - \chi_{lt}^- = 0 : (f_{lt}^{wc}); \quad \forall l \in \mathcal{L}^C \quad (55)$$

$$-1 \leq \beta_{fr(l),t} \leq 1 : (\Delta D_{bt}^+, \Delta D_{bt}^-); \forall b \in N \quad (56)$$

$$\begin{aligned} & \sum_{l \in (\mathcal{L}^F \cup \mathcal{L}^{PS}) | to(l)=b} \frac{a_{lt}^L}{x_l} \omega_{lt} - \sum_{l \in (\mathcal{L}^F \cup \mathcal{L}^{PS}) | fr(l)=b} \frac{a_{lt}^L}{x_l} \omega_{lt} \\ & + \sum_{l \in \mathcal{L}^C | to(l)=b} \frac{\sigma_{lt}^+}{x_l} - \sum_{l \in \mathcal{L}^C | fr(l)=b} \frac{\sigma_{lt}^+}{x_l} + \sum_{l \in \mathcal{L}^C | fr(l)=b} \frac{\sigma_{lt}^-}{x_l} \\ & - \sum_{l \in \mathcal{L}^C | to(l)=b} \frac{\sigma_{lt}^-}{x_l} = 0 : (\theta_{lt}^{wc}); \forall b \in N \end{aligned} \quad (57)$$

$$- \frac{a_{lt}^L}{x_l} \omega_{lt} + \eta_{lt}^+ - \eta_{lt}^- = 0 : (\psi_{lt}^{wc}); \forall l \in \mathcal{L}^{PS} \quad (58)$$

$$\sigma_{lt}^+, \sigma_{lt}^-, \chi_{lt}^+, \chi_{lt}^- \geq 0; \forall l \in \mathcal{L}^C \quad (59)$$

$$\pi_{lt}^+, \pi_{lt}^- \geq 0; \forall l \in (\mathcal{L}^F \cup \mathcal{L}^{PS}) \quad (60)$$

$$\gamma_{it}^+, \gamma_{it}^- \geq 0; \forall i \in I \quad (61)$$

$$\eta_{lt}^+, \eta_{lt}^- \geq 0; \forall l \in \mathcal{L}^{PS} \quad (62)$$

Formulation (51)–(62) is a mixed-integer nonlinear programming problem. Following well-known algebra results [37], the bilinear product $a_{lt}^L \sigma_{lt}^+$ for instance can be linearized in two steps. Firstly the auxiliary variable e_{lt}^+ is created to replace $a_{lt}^L \sigma_{lt}^+$ in (51). Secondly, the following constraints are included in the oracle to represent the linearization of the aforementioned bilinear product.

$$0 \leq \sigma_{lt}^+ - e_{lt}^+ \leq (1 - a_{lt}^L) M_l \quad (63)$$

$$0 \leq e_{lt}^+ \leq a_{lt}^L M_l \quad (64)$$

The same rationale is used to linearize the other bilinear products, namely $a_{lt}^L \sigma_{lt}^-$, $a_{lt}^L \chi_{lt}^+$, $a_{lt}^L \chi_{lt}^-$, $a_{lt}^L \omega_{lt}$, $a_{it}^G \gamma_{it}^+$, and $a_{it}^G \gamma_{it}^-$.

Once such linearizations are performed, the oracle is recast into a MILP problem.

Regarding the big-M values used in the aforementioned linearizations, it is worth mentioning that, as discussed in [31], if any of constraints (26)–(28) and (30) is modified in the right hand side by an infinitesimal value, the largest change in the objective function of the fifth level (24) will be limited to the aforementioned infinitesimal value multiplied by 2. This effect is because every variable f_{it}^{wc} is present in two nodal power balance constraints since each f_{it}^{wc} has a sending and a receiving bus. Therefore, big-M values associated with the linearizations of products $a_{it}^L \sigma_{it}^+$, $a_{it}^L \sigma_{it}^-$, $a_{it}^L \chi_{it}^+$, $a_{it}^L \chi_{it}^-$, and $a_{it}^L \omega_{it}$ can be set equal to 2. Likewise, any perturbation in the right hand side of (31) would lead to a change in the value of the objective function (24) limited to the magnitude of such perturbation. Consequently, the big-M values related to the linearizations of $a_{it}^G \gamma_{it}^+$, and $a_{it}^G \gamma_{it}^-$ can be set equal to 1.

ACKNOWLEDGMENT

The authors would like to thank FICO (Xpress-MP developer) for the academic partnership program with the Department of Electrical and Electronic Engineering of the Imperial College London.

REFERENCES

- [1] I. Konstantelos, R. Moreno, and G. Strbac, "Coordination and uncertainty in strategic network investment: Case on the North Seas Grid," *Energy Econ.*, vol. 64, pp. 131–148, May 2017.
- [2] B. Chen, J. Wang, L. Wang, Y. He, and Z. Wang, "Robust optimization for transmission expansion planning: Minimax cost vs. minimax regret," *IEEE Trans. Power Syst.*, vol. 29, no. 6, pp. 3069–3077, Nov. 2014.
- [3] F. D. Munoz, B. F. Hobbs, J. L. Ho, and S. Kasina, "An engineering-economic approach to transmission planning under market and regulatory uncertainties: WECC case study," *IEEE Trans. Power Syst.*, vol. 29, no. 1, pp. 307–317, Jan. 2014.
- [4] S. Dehghan, N. Amjadi, and A. J. Conejo, "Reliability-constrained robust power system expansion planning," *IEEE Trans. Power Syst.*, vol. 31, no. 3, pp. 2383–2392, May 2016.
- [5] A. Moreira, A. Street, and J. M. Arroyo, "An adjustable robust optimization approach for contingency-constrained transmission expansion planning," *IEEE Trans. Power Syst.*, vol. 30, no. 4, pp. 2013–2022, Jul. 2015.
- [6] L. J. Savage, "The theory of statistical decision," *J. Amer. Statist. Assoc.*, vol. 46, pp. 55–67, 1951.
- [7] G. Latorre, R. D. Cruz, J. M. Areiza, and A. Villegas, "Classification of publications and models on transmission expansion planning," *IEEE Trans. Power Syst.*, vol. 18, no. 2, pp. 938–946, May 2003.
- [8] R. Hemmati, R.-A. Hooshmand, and A. Khodabakhshian, "Comprehensive review of generation and transmission expansion planning," *IET Gener. Transm. Distrib.*, vol. 7, no. 9, pp. 955–964, Sep. 2013.
- [9] L. P. Garcés, A. J. Conejo, R. García-Bertrand, and R. Romero, "A bilevel approach to transmission expansion planning within a market environment," *IEEE Trans. Power Syst.*, vol. 24, no. 3, pp. 1513–1522, Aug. 2009.
- [10] L. P. Garcés, R. Romero, and J. M. Lopez-Lezama, "Market-driven security-constrained transmission network expansion planning," in *Proc. IEEE/PES Transm. Distrib. Conf. Expo.: Latin Amer.*, São Paulo, Brazil, 2010, pp. 427–433.
- [11] M. R. Hesamzadeh and M. Yazdani, "Transmission capacity expansion in imperfectly competitive power markets," *IEEE Trans. Power Syst.*, vol. 29, no. 1, pp. 62–71, Jan. 2014.
- [12] D. Pozo, E. E. Sauma, and J. Contreras, "A three-level static MILP model for generation and transmission expansion planning," *IEEE Trans. Power Syst.*, vol. 28, no. 1, pp. 202–210, Feb. 2013.
- [13] C. Ruiz and A. J. Conejo, "Robust transmission expansion planning," *Eur. J. Oper. Res.*, vol. 242, no. 2, pp. 390–401, 2015.
- [14] B. Chen and L. Wang, "Robust transmission planning under uncertain generation investment and retirement," *IEEE Trans. Power Syst.*, vol. 31, no. 6, pp. 5144–5152, Nov. 2016.
- [15] M. Sahraei-Ardakani and K. W. Hedman, "A fast LP approach for enhanced utilization of variable impedance based FACTS devices," *IEEE Trans. Power Syst.*, vol. 31, no. 3, pp. 2204–2213, May 2016.
- [16] M. Sahraei-Ardakani and K. W. Hedman, "Day-ahead corrective adjustment of FACTS reactance: A linear programming approach," *IEEE Trans. Power Syst.*, vol. 31, no. 4, pp. 2867–2875, Jul. 2016.
- [17] R. Moreno, Y. Chen, and G. Strbac, "Evaluation of benefits of coordinated dc ac flexible transmission systems with probabilistic security and corrective control," in *Proc. IET Int. Conf. Resilience Transm. Distrib. Netw.*, Sep. 2015, pp. 1–6.
- [18] R. Perez, "Power flow controllability and flexibility in the transmission expansion planning problem: A mixed-integer linear programming approach," Master's thesis, COPPE UFRJ, Electr. Eng. Dept., Rio de Janeiro, Brazil, 2014.
- [19] I. Konstantelos and G. Strbac, "Valuation of flexible transmission investment options under uncertainty," *IEEE Trans. Power Syst.*, vol. 30, no. 2, pp. 1047–1055, Mar. 2015.
- [20] G. Ayala and A. Street, "Energy and reserve scheduling with post-contingency transmission switching," *Elect. Power Syst. Res.*, vol. 111, pp. 133–140, 2014. [Online]. Available: <http://www.sciencedirect.com/science/article/pii/S0378779614000510>
- [21] D. E. Bell, "Regret in decision making under uncertainty," *Oper. Res.*, vol. 30, no. 5, pp. 961–981, Sep./Oct. 1982.
- [22] G. Loomes and R. Sugden, "Regret theory: An alternative theory of rational choice under uncertainty," *Econ. J.*, vol. 92, no. 368, pp. 805–824, Dec. 1982.
- [23] B. G. Gorenstin, N. M. Campodonico, J. P. Costa, and M. V. F. Pereira, "Power system planning under uncertainty," *IEEE Trans. Power Syst.*, vol. 8, no. 1, pp. 129–136, Feb. 1993.
- [24] J. M. Arroyo, N. Alguacil, and M. Carrión, "A risk-based approach for transmission network expansion planning under deliberate outages," *IEEE Trans. Power Syst.*, vol. 25, no. 3, pp. 1759–1766, Aug. 2010.
- [25] K. Bell, P. Roddy, and C. Ward, "The impact of generation market uncertainty on transmission system thermal constraints and plant procurement volumes," in *Proc. 39th CIGRE Session*, Paris, France, Aug. 2002.
- [26] "Electricity ten year statement 2014," National Grid, Report, 2014. [Online]. Available: <http://www2.nationalgrid.com/UK/Industry-information/Future-of-Energy/Electricity-ten-year-statement/ETYS-Archive/>
- [27] V. Rious, Y. Perez, and J. Glachant, "Power transmission network investment as an anticipation problem," *Rev. Netw. Econ.*, vol. 10, no. 4, pp. 1–21, 2011.
- [28] J. M. Morales, P. Pinson, and H. Madsen, "A transmission-cost-based model to estimate the amount of market-integrable wind resources," *IEEE Trans. Power Syst.*, vol. 27, no. 2, pp. 1060–1069, May 2012.
- [29] D. Pozo, J. Contreras, and E. Sauma, "If you build it, he will come: Anticipative power transmission planning," *Energy Econ.*, vol. 36, pp. 135–146, 2013.
- [30] Q. Wang, J.-P. Watson, and Y. Guan, "Two-stage robust optimization for N-k contingency-constrained unit commitment," *IEEE Trans. Power Syst.*, vol. 28, no. 3, pp. 2366–2375, Aug. 2013.
- [31] A. Street, A. Moreira, and J. M. Arroyo, "Energy and reserve scheduling under a joint generation and transmission security criterion: An adjustable robust optimization approach," *IEEE Trans. Power Syst.*, vol. 29, no. 1, pp. 3–14, Jan. 2014.
- [32] F. Bouffard, F. D. Galiana, and J. M. Arroyo, "Umbrella contingencies in security-constrained optimal power flow," in *Proc. 15th Power Syst. Comput. Conf.*, Liege, Belgium, Aug. 2005.
- [33] Case study input data. [Online]. Available: <https://drive.google.com/open?id=0BxgJO6PuetvKYW9SOG11dVpYekk>
- [34] Xpress Optimization Suite. [Online]. Available: <http://www.fico.com/>
- [35] "Whitepaper: Electricity capacity report," National Grid, Report, 2015. [Online]. Available: <https://www.emrdeliverybody.com/Capacity%20Markets%20Document%20Library/Electricity%20Capacity%20Report%202015.pdf>
- [36] A. Papavasiliou, S. S. Oren, and B. Rountree, "Applying high performance computing to transmission-constrained stochastic unit commitment for renewable energy integration," *IEEE Trans. Power Syst.*, vol. 30, no. 3, pp. 1109–1120, May 2015.
- [37] C. A. Floudas, *Nonlinear and Mixed-Integer Optimization: Fundamentals and Applications*. New York, NY, USA: Oxford Univ. Press, 1995.



Alexandre Moreira (S'12) received the Electrical Engineering and Industrial Engineering degrees from the Pontifical Catholic University of Rio de Janeiro (PUC-Rio), Rio de Janeiro, Brazil, in 2011. He received the M.Sc. degree from the Electrical Engineering Department, PUC-Rio, in 2014. He is working toward the Ph.D. degree in the Department of Electrical and Electronic Engineering, Imperial College London, London, U.K.

His research interests include decision making under uncertainty as well as power system economics, operation, and planning.

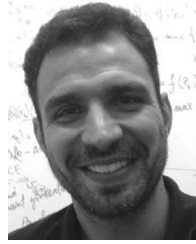

Alexandre Street (S'06–M'10–SM'17) received the M.Sc. degree and the D.Sc. degree in electrical engineering (operations research) from the Pontifical Catholic University of Rio de Janeiro (PUC-Rio), Rio de Janeiro, Brazil.

In the beginning of 2008, he joined PUC-Rio to teach optimization in the Electrical Engineering Department as an Assistant Professor. His research interests include power system economics, optimization methods, and decision making under uncertainty.



Goran Strbac (M'95) is a Professor of electrical energy systems at Imperial College, London, U.K. His current research interests include electricity generation, transmission and distribution operation, planning and pricing, and integration of renewable and distributed generation in electricity systems.



Ioannis Konstantelos (M'12) received the M.Eng. degree in electrical and electronic engineering and the Ph.D. degree in electrical energy systems from Imperial College, London, U.K., in 2007 and 2013, respectively.

His research interests include mathematical programming and statistical modeling techniques applied to planning of energy systems.



Rodrigo Moreno (M'05) received the B.Sc. and M.Sc. degrees from Pontificia Universidad Catolica de Chile, Santiago, Chile, and the Ph.D. degree from Imperial College London, London, U.K. He is currently an Assistant Professor in the Department of Electrical Engineering and Energy Center, Universidad de Chile and a Research Associate at Imperial College London. His research interests include power system optimization, reliability and economics, renewable energy, and the smart grid.